

# CHAIN PULLEY BLOCK

LET'S MAKE LIFTING SMARTER

# We Build Trust



## TO BE INNOVATIVE

Through steady research & development we have achieved international product design and so we are continuously innovating our product range.

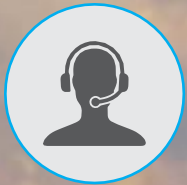

## TO BE CUSTOMER ORIENTED

Experience of more than 25 years of our professional engineers is put into each product, in response to our customer's refined needs.



## FAST DELIVERY SCHEDULE

Globe is equipped with vast efficient production line which is handled by skillful workers.



## SAFETY & HIGH STRENGTH

All equipments are designed as per IS safety standards as well as long life robust structural design.



## EASY MAINTAINANCE

During the design of the equipments, our R&D team always take care of the ease of maintenance & our efficient maintenance team makes it more competitive.

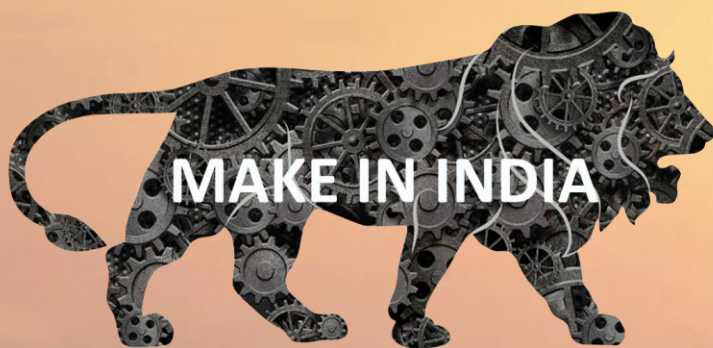

**MAKE IN INDIA**



# Chain Pulley Block Classic Series



Confirming to IS 3832 : 2005  
Model - CL

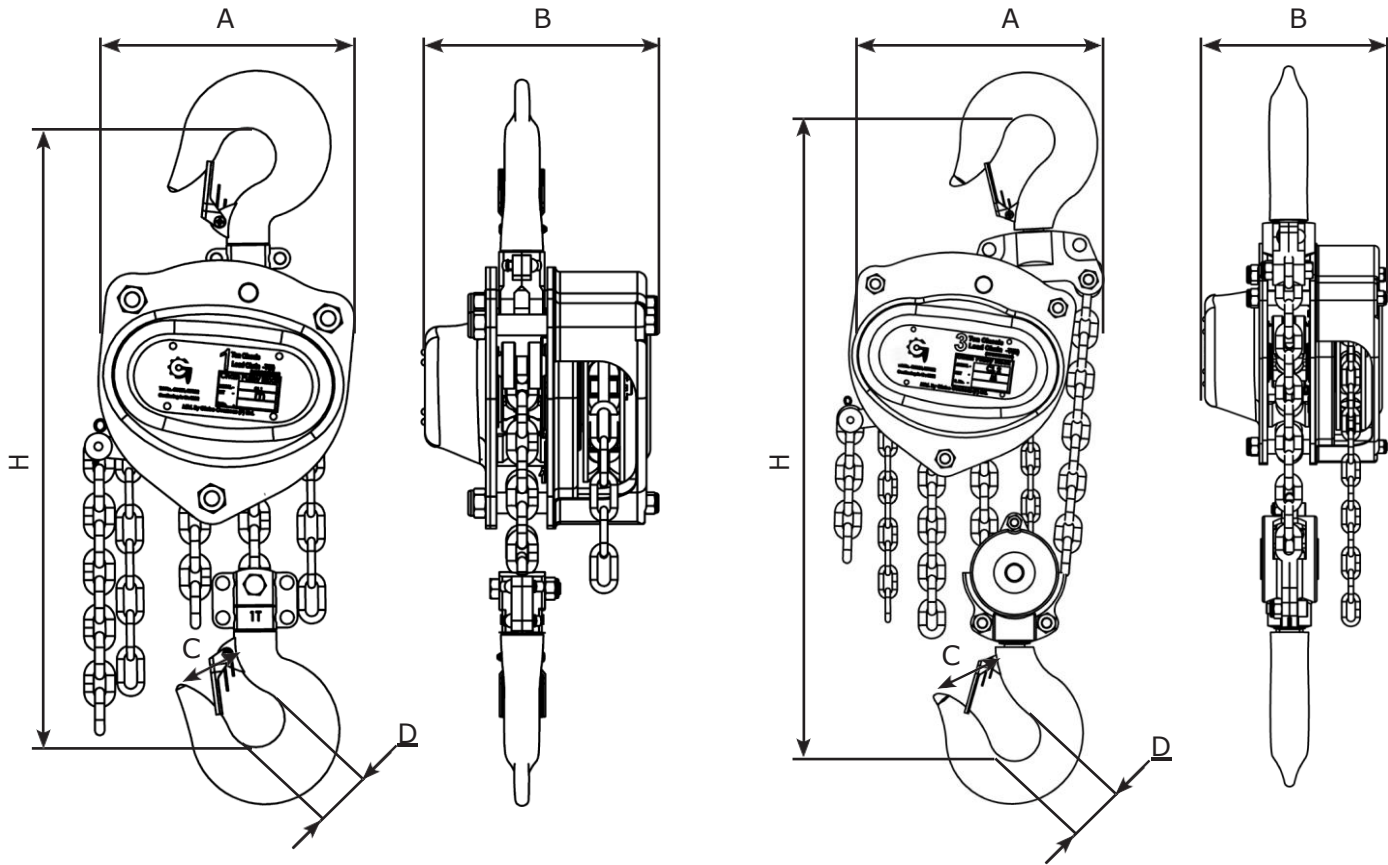

## TECHNICAL SPECIFICATION

### CHAIN PULLEY BLOCK – CLASSIC SERIES

Model	CL1	CL2	CL3S	CL3D	CL5	CL7.5	CL10	
Capacity (Ton)	1	2	3	3	5	7.5	10	
Standard lifting height (m)	3	3	3	3	3	3	3	
Running test load (Ton)	1.25	2.5	3.75	3.75	6.25	9.375	12.5	
Headroom H (mm)	415	500	580	605	770	865	865	
No. of fall	1	1	1	2	2	3	4	
Load Chain Ø & Pitch (mm)	6.3X19	8X23	10X30	8X23	10X30	10X30	10X30	
Hand Effort in (kg)	25	30	37	35	36	38	39	
Dimension (mm)	A	172	220	220	265	290	443	473
	B	155	178	178	209	193	192	192
	C	27	34	38	38	48	60	62
	D	36	46	50	50	63	80	82
Packing Measurement (LXWXH) (cm)	33X21X20	39X22X26	43X40X30	45X42X32	47X44X36	62X47X40	53X51X47	
Net weight (Kg)	13.5	20.5	26.5	33.5	45	74.5	80	
Extra Weight per meter of extra lift (kg)	2.2	3.6	2.9	3.6	5.1	7.2	9.3	

Note :- Due To Continuous development and improvement specification listed above may be changed without notice.

# Salient Features

- Gr. 80 Alloy steel load chain
- Light weight & compact
- Low headroom
- Minimum hand effort.
- Sturdy
- Smooth Running & Good Appearance

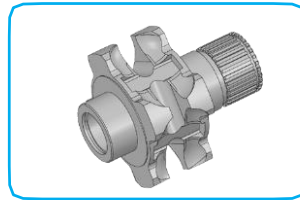

## LOAD CHAIN SPROCKET

Steel recommended as Per IS 3832, Ultra Fine Quality Fully Pocketed Cast Steel & Precisely Machined to suit calibrated load Chain & Roller Bearing for free rotation, reducing effort for lifting, Improved Life Cycle and smooth running.



## HOOK

Heavy Duty steel forged compact hook for Top & bottom hook assembly with safety latch, capable to withstand shock loads manufactured as per IS 15560-2005.

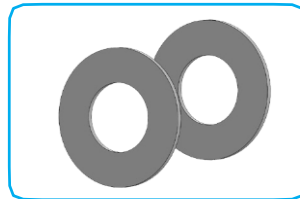

## SAFE BRAKING ARRANGEMENT

Self-actuating screw disc Type Mechanical Braking arrangement with non-asbestos based brake disc provides long lasting and high performance.

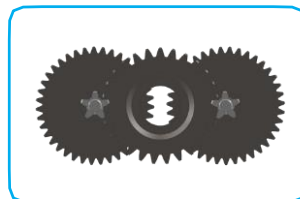

## GEAR SET

Highly efficient, compact and hard wearing Gears manufactured from alloy steel, Precisely machined and Processed.

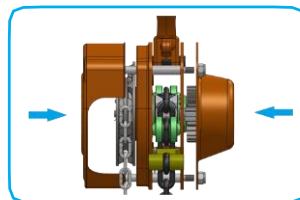

## TRIPLE PROTECTION COVER

Heavy duty Steel coated cover protects from atmospheric conditions, external shocks and improves life of complete chain block.



## CHAIN GUIDE ROLLER

Double Chain guide rollers ensures accurate alignments & smooth movement of load chain.



## RATCHET & PAWL ARRANGEMENT

2 Nos. Spring Loaded heavy duty heat treated pawl enhances the performance and improves safety in all positions.



## BEARINGS

High Quality steel housing ball and needle bearings improves efficiency.

